

Date Purchased _____ Machine Serial No. _____

Size of Pump _____ Options _____

The key number system in this parts book is arranged as follows:

- ◎ - Key numbers with two circles denotes main assemblies.
- - Key numbers with one circle are individual parts

Please order parts by number



4" ELECTRA KING

ELECTRA KING PUMP – 4ft ▪ 550-00-00-000
ELECTRA KING PUMP – 5ft ▪ 551-00-00-000
ELECTRA KING PUMP – 6ft ▪ 552-00-00-000
ELECTRA KING PUMP – 8ft ▪ 553-00-00-000
ELECTRA KING PUMP – 10ft ▪ 554-00-00-000
ELECTRA KING PUMP – 12ft ▪ 555-00-00-000
ELECTRA KING PUMP – 15ft ▪ 556-00-00-000

OPERATING INSTRUCTIONS:

1. Pump must turn counter-clockwise when looking down from top.
2. Fasten pump solid so it will not move when operating.
3. Make sure all moving parts are shielded.
4. Keep children and livestock away from pump.
5. Have an Electrician check amp draw when operating to make sure the motor has enough electricity.
6. Check bottom bearing for wear occasionally.
7. Keep belts snug but not overly tight.
8. **EXTREME DANGER** – Never enter a dirty manure spreader or storage tank – one breath of hydrogen sulphide gas is enough to kill. Have a ladder in your pit, so that if by accident you should fall in, you can get out.

ELECTRA KING COMPLETE

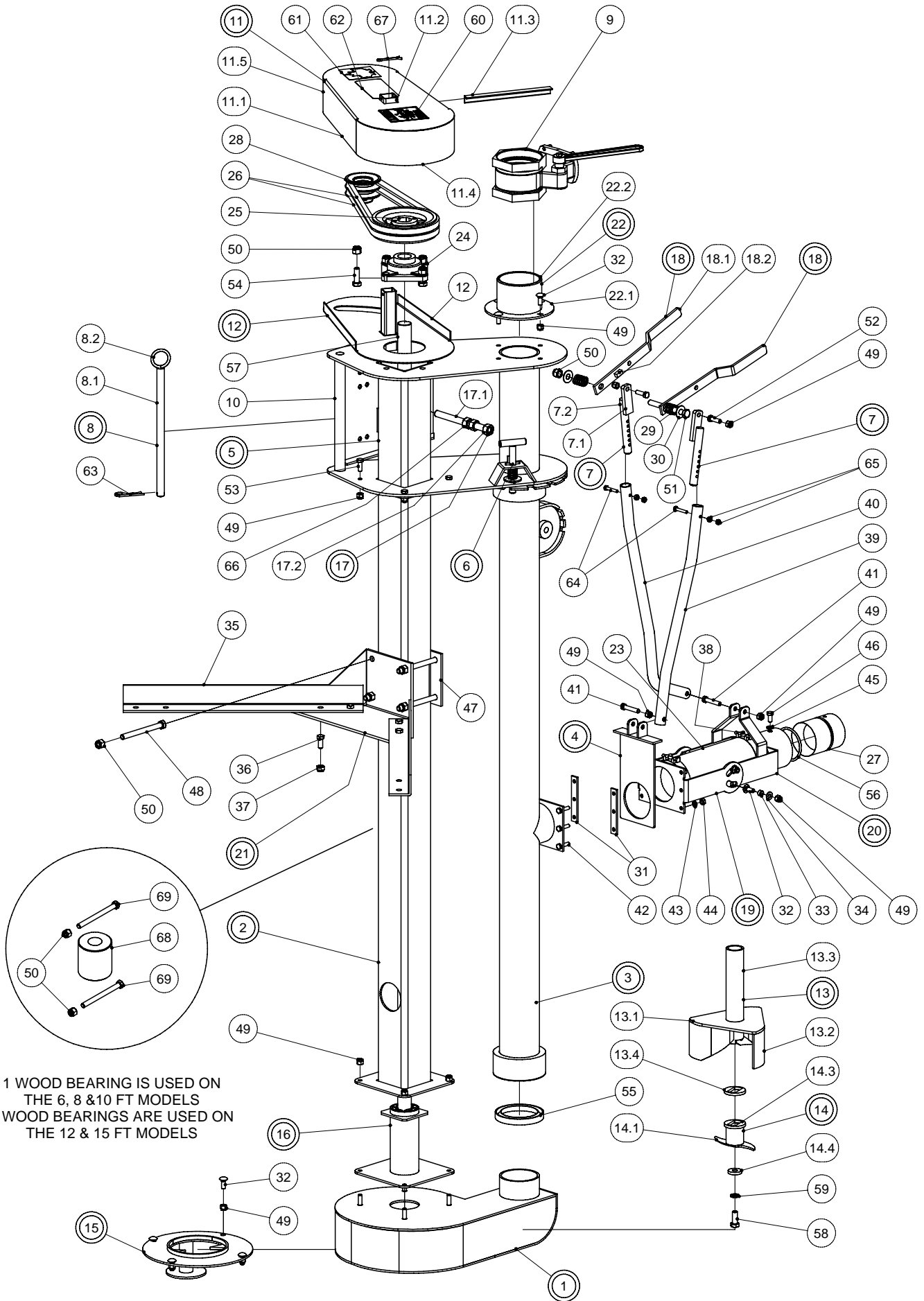

ELECTRA KING COMPLETE

PARTS LIST				PARTS LIST			
ITEM	PART NUMBER	DESCRIPTION	QTY	ITEM	PART NUMBER	DESCRIPTION	QTY
1	550-01-00-000	HOUSING ASSY	1	16	550-02-00-000	BEARING ASSY	1
2	550-03-00-000	4FT SHAFT TUBE ASSY	1	17	550-44-00-000	S.S. TENSION BOLT ASSY	1
	551-25-00-000	5FT SHAFT TUBE ASSY	*	17.1	550-44-00-093	S.S. TENSION BOLT	1
	552-26-00-000	6FT SHAFT TUBE ASSY	*	17.2	R08389	5/8-11 SS UNC HEX NUT	1
	553-27-00-000	8FT SHAFT TUBE ASSY	*	18	550-06-02-000	ADJUSTMENT HANDLE ASSY	2
	554-28-00-000	10FT SHAFT TUBE ASSY	*	18.1	550-06-02-022	HANDLE	1
	555-29-00-000	12FT SHAFT TUBE ASSY	*	18.2	550-06-02-023	HANDLE LOCK	1
	556-41-00-000	15FT SHAFT TUBE ASSY	*	19	550-12-00-000	VERTICAL DEF. OUTER BRKT ASSY	1
3	550-04-00-000	STANDPIPE ASSY-4FT MODEL	1	20	550-13-00-000	OUTER DEFLECTOR ASSY	1
	551-20-00-000	STANDPIPE ASSY-5FT MODEL	*	21	550-14-00-000	FLOOR BRKT ASSY	1
	552-21-00-000	STANDPIPE ASSY-6FT MODEL	*	22	550-49-00-000	FLANGED PIPE NIPPLE ASSY	1
	553-22-00-000	STANDPIPE ASSY-8FT MODEL	*	22.1	550-49-00-097	NIPPLE FLANGE	1
	554-23-00-000	STANDPIPE ASSY-10FT MODEL	*	22.2	R02098	4" TOE PIPE NIPPLE	1
	555-24-00-000	STANDPIPE ASSY-12FT MODEL	*	23	550-00-00-062	VERTICAL DEFLECTOR FLEX HOSE	1
	556-40-00-000	STANDPIPE ASSY-15FT MODEL	*	24	R20185	1 3/8 FLANGE BRG	1
4	550-10-00-000	VALVE GATE ASSY	1	25	R21062	2HBx6.4 SHEEVE w/ BUSH.-1 3/8 BORE	1
5	550-05-00-000	TOP TUBE AND PIPE ASSY	1	26	R20932	38B - V BELTS	2
6	550-05-01-000	LOCK PIN KIT	1	27	550-00-00-039	INNER CONE PIPE	1
7	550-07-00-000	ADJUSTING ROD ASSY	2	28	R21064	2 HB x 3.5 x 1 1/8 BORE PULLEY	1
7.1	550-07-00-024	ADJUSTMENT BRKT	1	29	R08387	1"OD X 1 1/4" LONG SPRING	2
7.2	550-07-00-025	ADJUSTMENT PIN	1	30	R08320	1/2" SS FLAT WASHER	2
8	230-08-00-000	MOTOR MOUNT PIN ASSY	1	31	550-00-00-035	VALVE SIDE BAR	2
8.1	230-08-00-064	MOTOR MOUNT PIN	1	32	R08392	3/8 x 1 UNC SS CARRIAGE BOLT	12
8.2	250-00-00-354	1/4 X 1 1/2" RING	1	33	550-00-00-089	SPACER PIPE	4
9	R09898	4" MANUAL BRASS BALL VALVE	1	34	R08231	3/8" SS FLAT WASHER	4
10	230-07-00-000	MOTOR MOUNT ASSY	1	35	230-00-00-077	FLOOR BRKT LEGS	2
11	550-16-00-000	GUARD ASSY	1	36	R08395	7/16 x 1 SS UNC HEX BOLT	4
11.1	550-16-00-046	GUARD TOP	1	37	R08229	7/16 UNC SS NYLOCK NUT	4
11.2	550-16-00-048	GUARD TUBE	1	38	R02481	4" CLAMP	2
11.3	550-16-00-049	GUARD REINFORCING ANGLE	1	39	550-08-00-026	4' MODEL VALVE CONTROL ROD	1
11.4	550-16-00-047	GUARD LARGE END BAND	1		551-30-00-073	5' MODEL VALVE CONTROL ROD	*
11.5	550-16-00-091	GUARD SMALL END BAND	1		552-31-00-074	6' MODEL VALVE CONTROL ROD	*
12	550-15-00-000	GUARD BASE ASSY	1		553-32-00-075	8' MODEL VALVE CONTROL ROD	*
13	550-17-00-000	IMPELLER ASSY	1		554-33-00-076	10' MODEL VALVE CONTROL ROD	*
13.1	230-31-00-127	IMPELLER BACK PLATE	1		555-34-00-077	12' MODEL VALVE CONTROL ROD	*
13.2	260-01-00-001	4" IMPELLER BLADE	3		556-42-00-086	15' MODEL VALVE CONTROL ROD	*
13.3	550-17-00-050	IMPELLER SLEEVE	1	40	550-09-00-027	4' MODEL DEFLECTOR ROD	1
13.4	550-17-00-051	SLOT WASHER	1		551-35-00-078	5' MODEL DEFLECTOR ROD	*
14	550-18-00-000	CUTTER BLADE ASSY	1		552-36-00-079	6' MODEL DEFLECTOR ROD	*
14.1	550-18-00-058	CUTTER BLADE	1		553-37-00-080	8' MODEL DEFLECTOR ROD	*
14.2	550-18-00-059	CUTTER BLADE TUBE	1		554-38-00-081	10' MODEL DEFLECTOR ROD	*
14.3	550-17-00-051	SLOT WASHER	1		555-39-00-082	12' MODEL DEFLECTOR ROD	*
14.4	550-18-00-060	CUTTER BLADE PLUG	1		556-43-00-087	15' MODEL DEFLECTOR ROD	*
15	550-19-00-000	COVER PLATE ASSY W/LEDGER	1	41	R08236	3/8 x 2 SS UNC HEX BOLT	2

ELECTRA KING COMPLETE

PARTS LIST			
ITEM	PART NUMBER	DESCRIPTION	QTY
42	R08248	5/16 x 1 1/4 SS UNC HEX BOLT	6
43	R08250	5/16" SS LOCK WASHER	6
44	R07884	5/16-18 SS UNC HEX NUT	6
45	R08319	3/8" SS LOCK WASHER	1
46	R07688	3/8 x 3/4 UNC HEX BOLT	1
47	550-00-00-096	FLOOR BRKT BACK PLATE	1
48	R08409	1/2 x 5 1/2 SS UNC HEX BOLT	4
49	R08228	3/8 UNC SS NYLOCK NUT	24
50	R08318	1/2 UNC SS NYLOCK NUT	9
51	R07644	1/2 x 5 UNC HEX BOLT	1
52	R08410	3/8 x 1 1/4 SS UNC HEX BOLT	2
53	R08317	3/8 x 1 SS UNC HEX BOLT	4
54	R08416	1/2 x 1 1/2 SS UNC HEX BOLT	4
55	R02855	4" RW GASKET	1
56	R22671	O-RING 78x5	1
57	550-00-00-052	SHAFT - 4 FT MODEL	1
	551-00-00-053	SHAFT - 5 FT MODEL	*
	552-00-00-054	SHAFT - 6 FT MODEL	*
	553-00-00-055	SHAFT - 8 FT MODEL	*
	554-00-00-056	SHAFT - 10 FT MODEL	*
	555-00-00-057	SHAFT - 12 FT MODEL	*
	556-00-00-088	SHAFT - 15 FT MODEL	*
58	R08217	1/2 x 1 1/4 SS UNC HEX BOLT	1
59	R08414	1/2" SS LOCK WASHER	1
60	R21521	"ROTATING DRIVE LINE" DECAL	1
61	R09508	"MADE IN CANADA" DECAL - LARGE	1
62	R09692	"CAUTION" - "ROTATING CCW" DECAL	1
63	R07948	5/32 HAIR PIN	1
64	R08404	1/4 x 1 1/2 SS UNC HEX BOLT	2
65	R08298	1/4-20 SS UNC HEX NUT	4
66	R08389	5/8-11 SS UNC HEX NUT	2
67	R08015	3/16 x 2 SS COTTER PIN	1
68	R22239	1 3/8" WOOD BRG	1
69	R08406	1/2 x 5 SS UNC HEX BOLT	2

SHAFT TUBE ASSY

4FT SHAFT TUBE ASSY
550-03-00-000

5FT SHAFT TUBE ASSY
551-25-00-000

6FT SHAFT TUBE ASSY
552-26-00-000

8FT SHAFT TUBE ASSY
553-27-00-000

10FT SHAFT TUBE ASSY
554-28-00-000

12FT SHAFT TUBE ASSY
555-29-00-000

15FT SHAFT TUBE ASSY
556-41-00-000

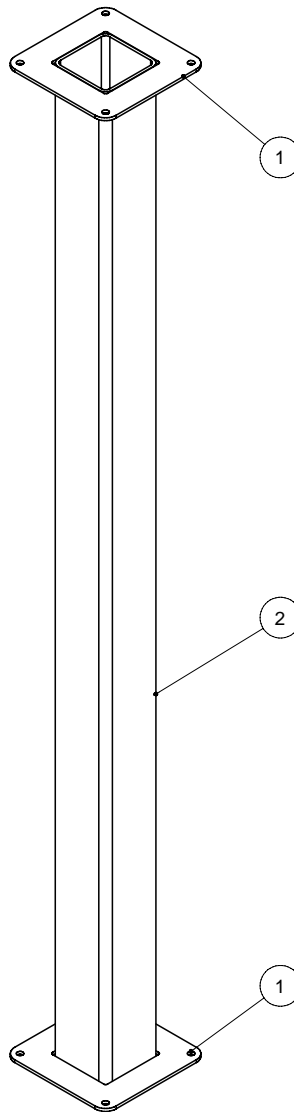

PARTS LIST			
ITEM	PART NUMBER	DESCRIPTION	QTY
1	550-03-00-009	SHAFT TUBE FLANGE	2
2	550-03-00-008	SHAFT TUBE-4FT PUMP	1
	551-25-00-068	SHAFT TUBE-5FT PUMP	*
	552-26-00-069	SHAFT TUBE-6FT PUMP	*
	553-27-00-070	SHAFT TUBE-8FT PUMP	*
	554-28-00-071	SHAFT TUBE-10FT PUMP	*
	555-29-00-072	SHAFT TUBE-12FT PUMP	*
	556-41-00-085	SHAFT TUBE-15FT PUMP	*

STANDPIPE ASSY

4FT STANDPIPE ASSY
550-04-00-000

5FT STANDPIPE ASSY
551-20-00-000

6FT STANDPIPE ASSY
552-21-00-000

8FT STANDPIPE ASSY
553-22-00-000

10FT STANDPIPE ASSY
554-23-00-000

12FT STANDPIPE ASSY
555-24-00-000

15FT STANDPIPE ASSY
556-40-00-000

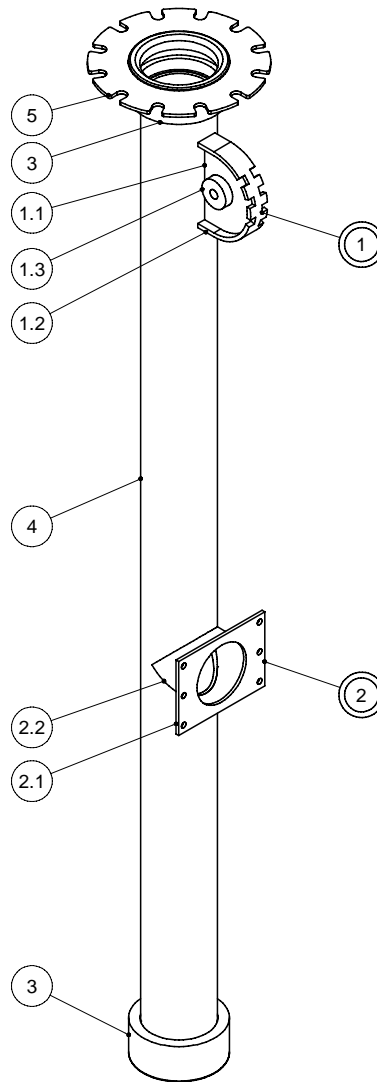

PARTS LIST			
ITEM	PART NUMBER	DESCRIPTION	QTY
1	550-06-01-000	ADJUSTMENT BRKT ASSY	1
1.1	550-06-01-019	MOUNT PLATE	1
1.2	550-06-01-020	NOTCH PLATE	1
1.3	550-06-01-021	SPACER SLEEVE	1
2	550-11-00-000	VALVE BACK PLATE & TEE ASSY	1
2.1	550-11-00-032	VALVE BACK PLATE	1
2.2	550-11-00-031	TEE PIPE	1
3	550-04-00-011	4" COUPLING BASE TUBE	2
4	550-04-00-010	STANDPIPE-4FT MODEL	1
	551-20-00-063	STANDPIPE-5FT MODEL	*
	552-21-00-064	STANDPIPE-6FT MODEL	*
	553-22-00-065	STANDPIPE-8FT MODEL	*
	554-23-00-066	STANDPIPE-10FT MODEL	*
	555-24-00-067	STANDPIPE-12FT MODEL	*
	556-40-00-084	STANDPIPE-15FT MODEL	*
5	550-04-00-012	SLOTTED ADJUSTMENT RING	1

FAN HOUSING & BEARING ASSY

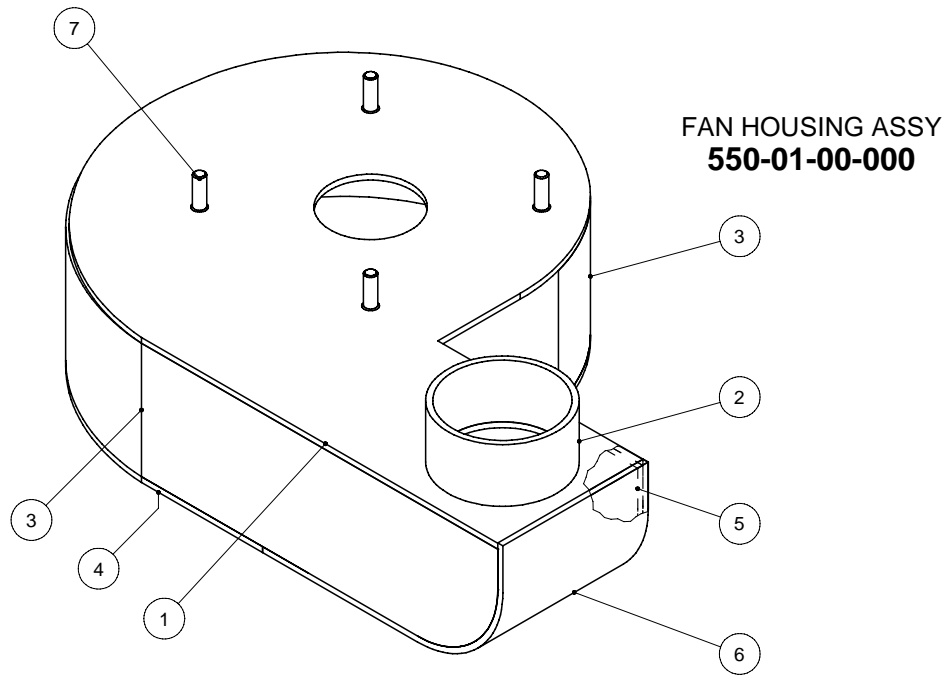

PARTS LIST			
ITEM	PART NUMBER	DESCRIPTION	QTY
1	550-01-00-001	FAN HOUSING TOP PLATE	1
2	550-01-00-005	STUB TUBE	1
3	550-01-00-002	HOUSING BAND	1
4	260-14-01-042	CHT FAN HOUSING BOTTOM PLATE	1
5	550-01-00-004	FILLER BAND	1
6	550-01-00-003	HOUSING END	1
7	R08403	3/8 X 1 1/4" S.S.FLAT HEAD SLOTTED	4

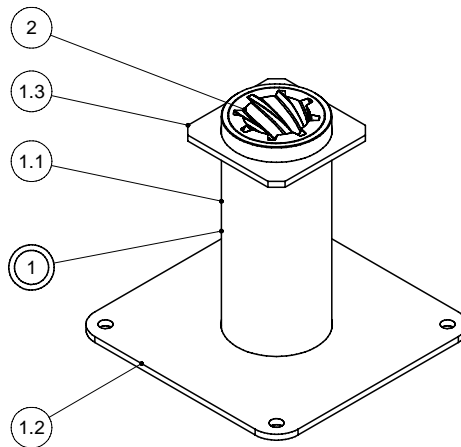

**BEARING KIT
550-02-00-000**

PARTS LIST			
ITEM	PART NUMBER	DESCRIPTION	QTY
1	550-02-01-000	MARINE BRG HOLDER ASSY	1
1.1	250-76-34-180	URETHANE BRG SLEEVE	1
1.2	550-02-01-006	BRG TUBE LOWER FLANGE	1
1.3	550-02-01-007	BEARING TOP PLATE	1
2	R20280	URETHANE	1

COVER, GUARD, BRACKET ASSY

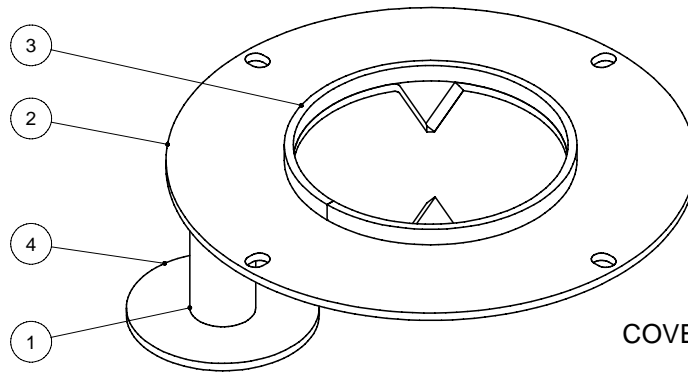

**COVER PLATE ASSY w/ LEDGER
550-19-00-000**

PARTS LIST			
ITEM	PART NUMBER	DESCRIPTION	QTY
1	230-06-00-059	FOOT SPACER	1
2	550-19-00-061	COVER PLATE W/LEDGER PLATE	1
3	550-19-00-083	COVER PLATE RING	1
4	230-06-00-060	FOOT	1

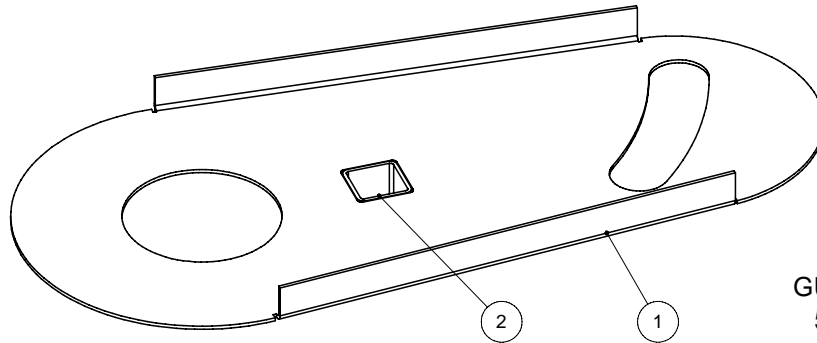

**GUARD BASE ASSY
550-15-00-000**

PARTS LIST			
ITEM	PART NUMBER	DESCRIPTION	QTY
1	550-15-00-043	GUARD BASE PLATE	1
2	550-15-00-044	OUTER TUBE	1

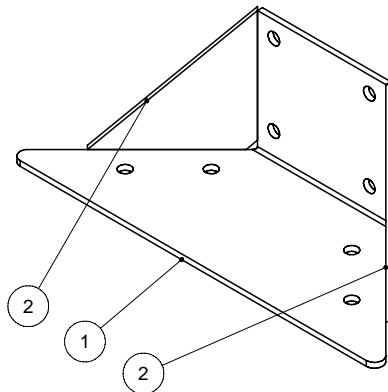

**FLOOR BRACKET ASSY
550-14-00-000**

PARTS LIST			
ITEM	PART NUMBER	DESCRIPTION	QTY
1	550-14-00-041	FLOOR BASE BRKT	1
2	550-14-00-042	FLOOR BRKT GUSSET	2

TOP TUBE & PIPE ASSY

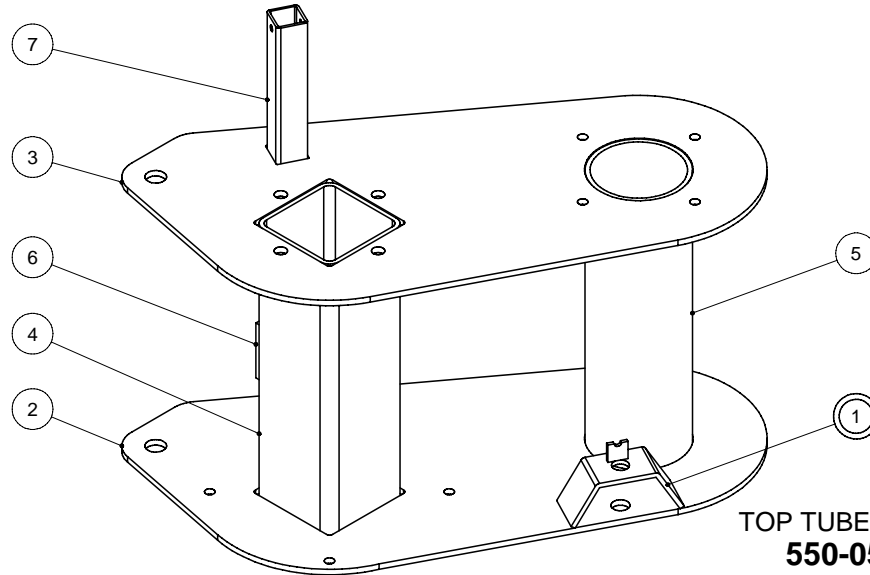

**TOP TUBE & PIPE ASSY
550-05-00-000**

PARTS LIST			
ITEM	PART NUMBER	DESCRIPTION	QTY
1	242-17-17-000	SIDE LOCK BRACKET ASSY	1
2	550-05-00-013	UPPER TUBE FLANGE	1
3	550-05-00-014	TOP TUBE FLANGE	1
4	550-05-00-015	STUB SQ TUBE	1
5	550-05-00-016	TOP TUBE	1
6	550-05-00-018	TENSION ROD BRKT	1
7	550-05-00-040	GUARD MAIN TUBE	1

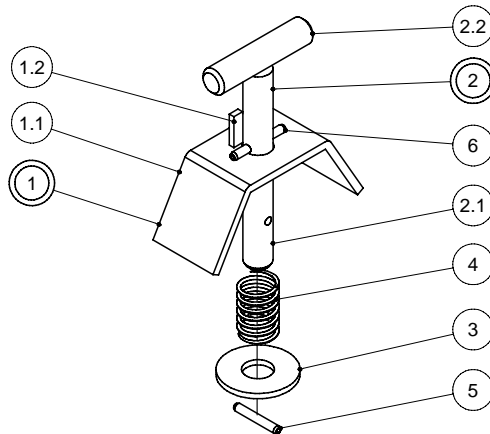

**SIDE LOCK BRACKET KIT
550-05-01-000**

PARTS LIST			
ITEM	PART NUMBER	DESCRIPTION	QTY
1	242-17-17-000	SIDE LOCK BRACKET ASSY	1
1.1	242-17-17-193	SIDE LOCK BRACKET	1
1.2	242-17-17-194	PIN STOP	1
2	550-05-02-000	SIDE LOCK PIN ASSY	1
2.1	550-05-02-092	LOCK PIN	1
2.2	242-17-18-196	PIN HANDLE	1
3	R07826	5/8 FLAT WASHER	1
4	R08027	7/8 x 1 3/8 COMP. SPRING	1
5	R07950	3/16 x 1 1/4 ROLL PIN	1
6	R07943	3/16 x 1 1/2 ROLL PIN	1

AGITATOR PARTS

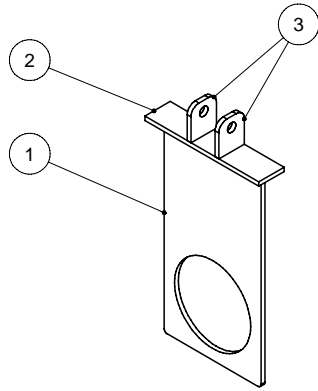

VALVE GATE ASSY
550-10-00-000

PARTS LIST			
ITEM	PART NUMBER	DESCRIPTION	QTY
1	550-10-00-028	S.S. VALVE GATE	1
2	550-10-00-029	VALVE GATE TOP PLATE	1
3	550-10-00-030	VALVE GATE LUG	2

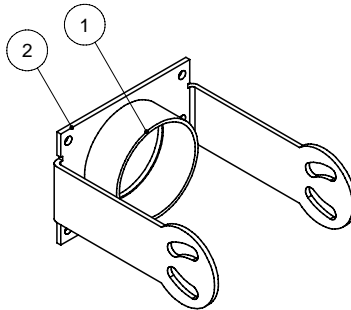

VERTICAL DEFLECTOR OUTER BRACKET ASSY
550-12-00-000

PARTS LIST			
ITEM	PART NUMBER	DESCRIPTION	QTY
1	550-12-00-034	VALVE EXTENSION TUBE	1
2	550-12-00-033	VERTICAL DEFLECTOR OUTER BRKT	1

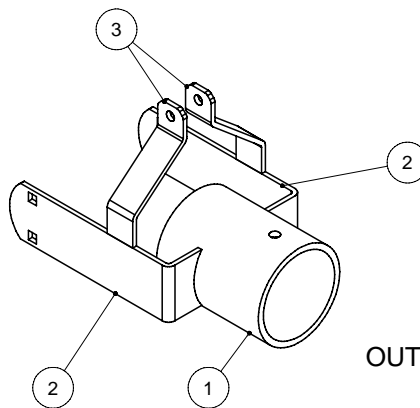

OUTER DEFLECTOR ASSY
550-13-00-000

PARTS LIST			
ITEM	PART NUMBER	DESCRIPTION	QTY
1	550-13-00-037	INNER PIVOT EXTENSION PIPE	1
2	550-13-00-036	INNER PIVOT BRKT	2
3	550-13-00-038	PIVOT ROD BRKT	2

GUARANTEE

All Husky Farm Equipment manufactured by Husky Farm Equipment Limited is guaranteed. Guarantee covers all the replacement cost or repair of all parts said to be defective from manufacture. Guarantee also covers labour installing said parts, if installed at Husky Manufacturing plant. Time and use is the essence of the guarantee. If equipment is used on a private property for an individual's use, guarantee will be in effect for twelve months from date of invoice. If equipment is used for commercial use to do custom work for money then guarantee will be in effect for three months only from date of invoice.

EXEMPTIONS FROM GUARANTEE

Cost of transportation of equipment to or from Husky Farm Equipment Limited either by customer or by Husky's service staff or cost of mail or public transportation is not covered. Tires and electric or hydraulic motors are covered by manufacturer's warranty and although Husky may assist to get warranty, Husky will not be responsible other than that allowed by manufacturer's warranty. Items subject to normal wear from use not covered by guarantee if faulty part is simply worn.